

UNDERCOUNTER FREEZER (0°F)

Model: SWF32N-U

Natural Refrigerant R-290 Model

32" Undercounter Freezer with Solid Door

Stainless steel front, top and end panels, aluminum back and interior.



Options and Accessories

(upcharge and lead times may apply)

Stainless steel interior	Stainless steel shelves
Stainless steel back	Door lock
Additional epoxy coated steel shelves	
Special electrical requirements (consult factory)	

Consult factory for other model configurations, options and accessories.

Project Name:

Model Specified:

Location:

Item No:

Quantity:

AIA #:

SIS #:

Standard Model Features

REFRIGERATION SYSTEM

Performance rated refrigeration system

Natural, environmentally safe,
high efficiency R-290 refrigerant¹

Automatic, hot gas condensate evaporator

Non-corrosive, plasticized fin evaporator coil

Easily serviceable, back mounted compressor

CABINET ARCHITECTURE

2" non-CFC polyurethane foam insulation

Smooth, polished chrome door handle

Spring loaded, self closing door

Magnetic snap in Santoprene™ door gasket

Heavy duty, epoxy coated steel shelf

Completely enclosed, vented and removable case back

1 3/8" diameter plate casters (factory installed)

MODEL FEATURES

Field rehingeable door

Electronic controller with digital display & hi/low alarm

Automatic electric defrost

2" high, bottom mounted front breather air divider

¹ R-290 refrigerant meets all federal and state regulatory requirements.

Continental[®]
Refrigerator

Toll-Free: 800-523-7138
Phone: 215-244-1400
Fax: 215-244-9579

539 Dunksferry Road
Bensalem, PA 19020
www.continentalrefrigerator.com

APPROVAL:

Model Specifications

DIMENSIONAL DATA

Net Capacity (cubic feet)	9.0 (253 cu l)
Width, Overall (inches)	32 (813 mm)
Depth, Overall (inches) (including handle & bumpers)	32 $\frac{3}{16}$ (818 mm)
Height, Overall (inches) (including 1 $\frac{3}{8}$ " plate casters)	31 $\frac{13}{16}$ (808 mm)
Shelf Area (square feet)	3.9 (0.4 sq m)
Number of Shelves	1
Number of Doors	1
Interior Depth (inches)	See Drawing
Interior Height (inches)	26 $\frac{1}{4}$ (667 mm)
Interior Width (inches)	28 (711 mm)

REFRIGERANT DATA

Condensing Unit Size (H.P.)	$\frac{1}{3}$
Capacity (BTU per hour)*	1800

ELECTRICAL DATA

Voltage (International)	115/60/1 (220/50/1)
Total Amps (International)	5.6 (3.6)
Defrost Amps (International)	4.8 (2.4)
10 ft. Cord/Plug [attached] (International)	Yes (No)

SHIPPING DATA

Weight (pounds)	221 (100 kg)
Height - Crated (inches)	43 $\frac{1}{4}$ (1099 mm)
Width - Crated (inches)	40 (1016 mm)
Depth - Crated (inches)	37 $\frac{1}{4}$ (946 mm)

* Rating @ -15°F evaporator, 90°F ambient
Figures in parentheses reflect metric equivalents rounded to the nearest whole unit.



Equipped with one NEMA-5-15P Plug
(varies by country)

Model Plan Views

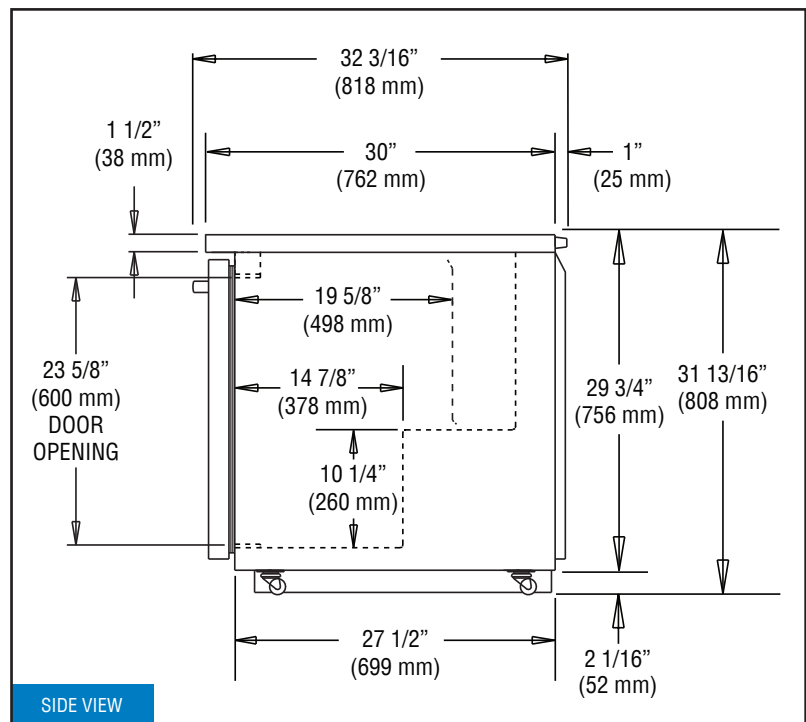
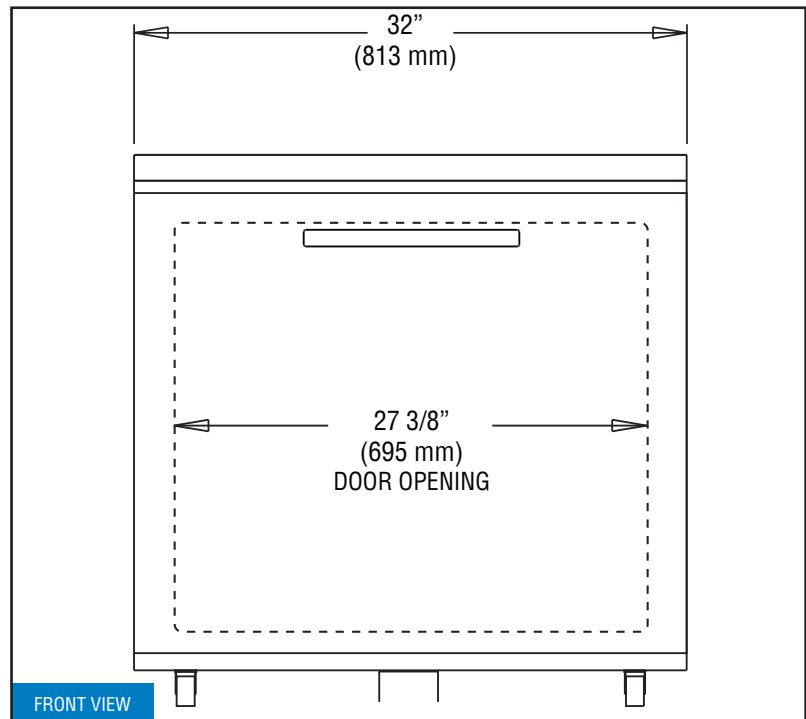

NOTE: For proper operation, the area under and in front of the cabinet **must** not be obstructed in any way.

Continental
Refrigerator

Toll-Free: 800-523-7138
Phone: 215-244-1400
Fax: 215-244-9579

539 Dunkserry Road
Bensalem, PA 19020
www.continentalrefrigerator.com

Due to our continued efforts in developing innovative products, specifications subject to change without notice.



© Copyright 2021. Continental Refrigerator.
A Division of National Refrigeration & Air Conditioning Products, Inc.

REVISED: 5/16/2022